

User's Manual

PPC-1573T 15.1" TFT Low Power 1GHz Panel PC

COPYRIGHT[©]

All rights reserved. The information contained in this guide has been validated and reviewed for accuracy. No patent liability is assumed with respect to the use of the information contained herein. While every precaution has been taken in the preparation of this guide, the Manufacturer assumes no responsibility for errors or omissions.

No part of this publication may be reproduced, stored in a retrieval system, or transmitted in any form or by any means, electronic, mechanical, photocopying, recording, or otherwise, without the prior written permission of NAGASAKI IPC.

TRADEMARK[™]

Intel[®], Pentium[®] and MMX[®] are registered trademarks of Intel[®] Corporation.

Microsoft[®] and Windows[®] are registered trademarks of Microsoft Corporation.

All products and company names are trademarks or registered trademarks of their respective holders.

These specifications are subject to change without notice.

Table of Contents

Chapter 1 General Information	
1-1 Pictures of PPC-1573T	1
1-2 General	2
1-3 Embedded Board Features	2
1-4 Embedded Board Specifications	3
Chapter 2 Hardware Installation Process	
2-1 CPU Installation	5
2-2 Memory Module Installation	6
2-3 Setting Jumpers and DIP Switches	7
Chapter 3 Board Layout	
3-1 Jumper Setting	10
Chapter 4 Connector's Description	
4-1 Connector Location	13
Chapter 5 Power Supply	
5-1 Pictures of Power Supply	24
Chapter 6 Touch Panel	
6-1 Touch Panel Description	25
Chapter 7 AWARD BIOS SETUP	
7-1 BIOS Instructions	30
7-2 Main Menu	30
7-3 Standard CMOS Features	33
7-4 IDE Adapters	36
7-5 Advanced BIOS Features	38
7-6 Advanced Chipset Features	41
7-7 Integrated Peripherals	45
7-8 Power Management Setup	47
7-9 PnP/PCI Configurations	52
7-10 PC Health Status	54
7-11 Frequency/Voltage Control	56
7-12 Load Fail-Safe Defaults	57
7-13 Load Optimized Defaults	57
7-14 Supervisor/User Password Setting	58
7-15 Exit Selecting	59

Chapter 1 General Information

1-1 Pictures of PPC-1573T



100% water-proof front
IP- 66, 65, 56, NEMA- 4, 12
Low power 1Ghz CPU



With or Without
Thick Aluminum bezel
Anti-Vibration, Anti-Shock



I/O ports with PCI slot
(PCMCIA card is option)



Swing Arm is optional



NASA-6822 Low Power 1GHz EBX board

1-2 General

- ◆ Dimensions: 425 x 465 x 256 mm(W x H x D)
- ◆ Weight: 7.5kg
- ◆ Type: 15" color TFT
- ◆ Max. Resolution: 1024 x 768
- ◆ Luminance (cd/m²): 200-250 cd/m²
- ◆ Color : Black
- ◆ Water-Proof front panel: Meet IP- 65, 56; NEMA-4, 12 water resistant EIA standard.
- ◆ Touch screen : optional 5-wire / 6-wire analog resistive touchscreen
- ◆ 1 expansion PCI slot for optional 32-bit Cardbus PCMCIA slot

1-3 Embedded Board Features

- ◆ Socket 370 : for VIA[®] Low Power Nehemiah 1Ghz Processor
- ◆ Chipset : VIA[®] VT8623 + VT8235 AGPset (CLE266)
- ◆ Support 512MB DDR SDRAM (Max.) Memory
- ◆ Front Side Bus Frequency: 100/133 MHz
- ◆ VIA[®] VT8623 chip integrated LVDS/TTL panel interface
- ◆ CRT VGA supported
- ◆ AGP 8x supported
- ◆ Video memory : 32MB / 64MB video share memory selected in BIOS

- ◆ Hardware MPEG-II engine on chip
- ◆ Dual 10/100 Mbps Ethernet interface using Realtek® RTL8100BL chip
- ◆ AC97 Audio
- ◆ 4 x COM ports : 2 external, 2 pin header on board, 3 x RS232 + 1x RS232/422/485
- ◆ 4 x USB2.0 exposed
- ◆ Software programmable watchdog timer
- ◆ S-Video TV-out Function : this features is only available from the second version
- ◆ Single DC 19V Power Input
- ◆ PS2 Keyboard and PS/2 Mouse Connector
- ◆ 1 x Printer Port
- ◆ 1 x 44pin IDE Connector , 1 x 40pin IDE Connector
- ◆ Hardware Monitoring
- ◆ 1 external speaker out port

1-4 Embedded Board Specifications

- ◆ **Processor:**
 - Socket 370 Processor for VIA® Low Power Nehemiah 1Ghz Processor
- ◆ **System Chipset:**
 - VIA® CLE266, VT8623(northbridge chip), VT8235 (southbridge chip)
- ◆ **Front Side Bus:**
 - 66/100/133 MHz
- ◆ **Memory:**
 - 184pin DIMM sockets supports PC-200 / 266 /333 DDR SDRAM(Auto).
 - Support up to 512MB high speed Double Data Rate SDRAM (Max).
- ◆ **LCD/VGA Function:**
 - VIA® VT8623 integrated Video Accelerators controller
 - Support LVDS / TTL panel interface
- ◆ **LAN Function:**
 - Realtek® RTL8100BL Ethernet controller
 - 2 RJ45 Ports for 10/100Base-TX Ethernet
- ◆ **Onboard I/O:**
 - On-Chip I/O integrated with K/B, Mouse, Parallel and 4 Serial ports
- ◆ **Onboard PCI / IDE:**
 - VIA® VT8235 Southbridge Controller
 - PCI rev2.2 Compliant
 - PCI Bus IDE Port with PIO / ATA-100 x 2 (Up to 4 Devices)
- ◆ **I/O Connector:**
 - 2 x 9-pin D-Sub Serial connector 2x 10-pin Pinheader(RS232 x 3,RS232 or RS485 x 1)
 - 2 x RJ-45 Ethernet connector
 - 15-pin D-Sub VGA connector
 - PS/2 Mouse and PS/2 Keyboard
- ◆ **USB2.0 Ports:**
 - 4 x USB2.0 ports
- ◆ **BIOS:**
 - Award Plug & Play BIOS
- ◆ **Extended Function:**
 - Hardware Monitoring function
 - IrDA by pin-head

Chapter 2 Hardware Installation Process

2-1 CPU Installation

Carefully follow the steps below in order to install the CPU:

1. Check and confirm that the jumpers are correctly set for the CPU you are going to install (figure 3).
2. Lift the releasing lever of the Socket 370.
3. Align the pins of the CPU against the pinholes of the Socket 370. Be sure to pay attention to the orientation of the CPU.

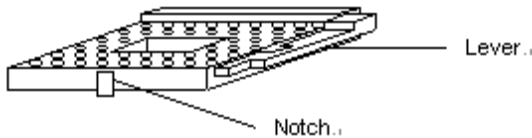

Figure 3: CPU Socket

4. Push down the CPU into the Socket 370.
5. Push down the release lever and lock it against the key hook.
6. Hook the hole in ZIF clip for the CPU cooling fan onto the notch on the socket 370.
7. Place the CPU cooling fan atop the CPU surface.
8. Push down the opposite side of the ZIF clip and hook it.
9. Slide the head of the clip to left and lock it.
10. Connect the cooling fan cable to the socket as shown below. Be careful not to place the cable on the CPU cooling fan.

Removing a CPU:

1. Before removing the CPU, turn off the NASA-6822 Series power; then wait for about 20 minutes until the heat radiation plate of the cooling fan and the CPU cool down.
2. To remove the CPU, lift the releasing lever of the Socket 370.

Note: The CPU and the heat radiation plate are hot. They may cause burns.

To remove the CPU, reverse the installation steps.

2-2 Memory Module Installation

Figure 5 display the notch marks and what they should look like on your DIMM memory module.

DIMMs have 184-pins and two notches, that will match with the onboard DIMM socket. DIMM modules are installed by placing the chip firmly into the socket at a 90-degree angle and pressing straight down (figure 6) until it fits tightly into the DIMM socket.

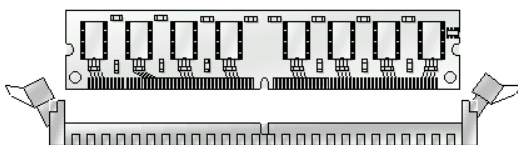

Figure 5: DIMM Memory and 184-pins Socket

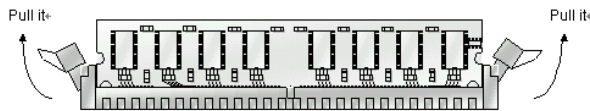

Figure 6: Memory Installation

Carefully follow the steps below in order to install the DIMMs:

1. To avoid generating static electricity and damaging the DIMM, ground yourself by touching a grounded metal surface or using a ground scrap before you touch the DIMM.
2. Do not touch the connector of the DIMM. Dirt residue may cause a malfunction.
3. Hold the DIMM with its notch to the front side of the NASA-6822 Series and insert it completely into the socket. A DIMM should be inserted into the inner socket first. Guiding the hole at each end of the DIMM over the retaining post at each end of the DIMM socket.
4. If you install two DIMMs, install the second DIMM using the same procedure as above.
5. If DIMM does not go in smoothly, do not force it. Pull it all the way out and try again.
6. Make sure the DIMM is properly installed and locked by the tabs on both sides of the socket.

Removing a DIMM:

To remove the DIMM, use your fingers or a small screwdriver to carefully push away the plastic tabs that secure the DIMM at each end. Lift it out of the socket.

Make sure you store the DIMM in an anti-static bag and must be populated the same size and manufactory of memory modules. .

2-3 Setting Jumpers and DIP Switches

There are jumpers and DIP-switches on the system board of the NASA-6822 Series. You can set the jumpers to make the necessary operations.

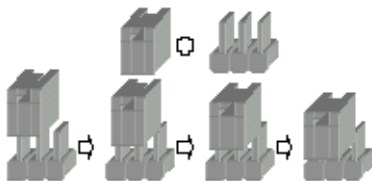

Figure 7: Jumper Connector

For any three-pin jumpers (figure 7), the jumper setting is 1-2 when the jumper connects pins 1 and 2. The setting is 2-3 when pins 2 and 3 are connected and so on. You see a number “ 1 “ and a “ 3 “ printed on the circuit board to identify these pins. And also, there is a second way of indication – one of the lines surrounding jumpers is thick, which indicates pin NO.1.

To move a jumper from one position to another, use needle-nose pliers or tweezers to pull the pin cap off the pins and move it to the desired position.

Chapter 3 Board Layout

I/O Ports and Location

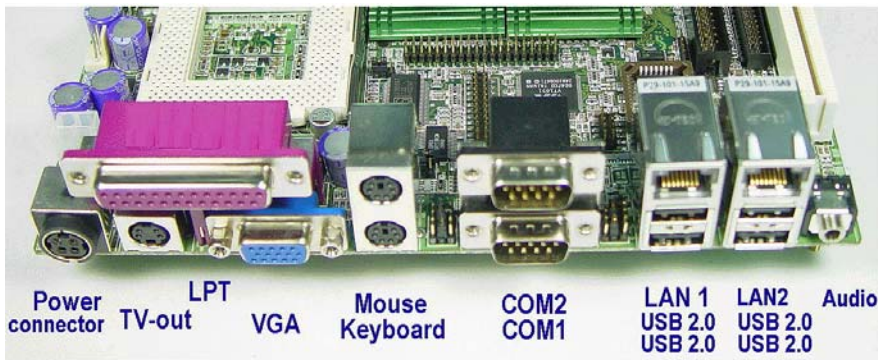

3-1 Jumper Setting

Table for Jumper Location Description:

Use the information in the following table to change the jumpers and the DIP switch.

Jumpers	Functions
JBAT1	Clear CMOS Setting Select
JP1	LCD Panel Voltage Select
J2	Power Bottom
J3	Reset
J6,J7.J8	COM2 RS232/422/485
J11	COM4 Setting Select
J12	COM1 Setting Select
J13	COM3 Setting Select
J14	COM2 Setting Select

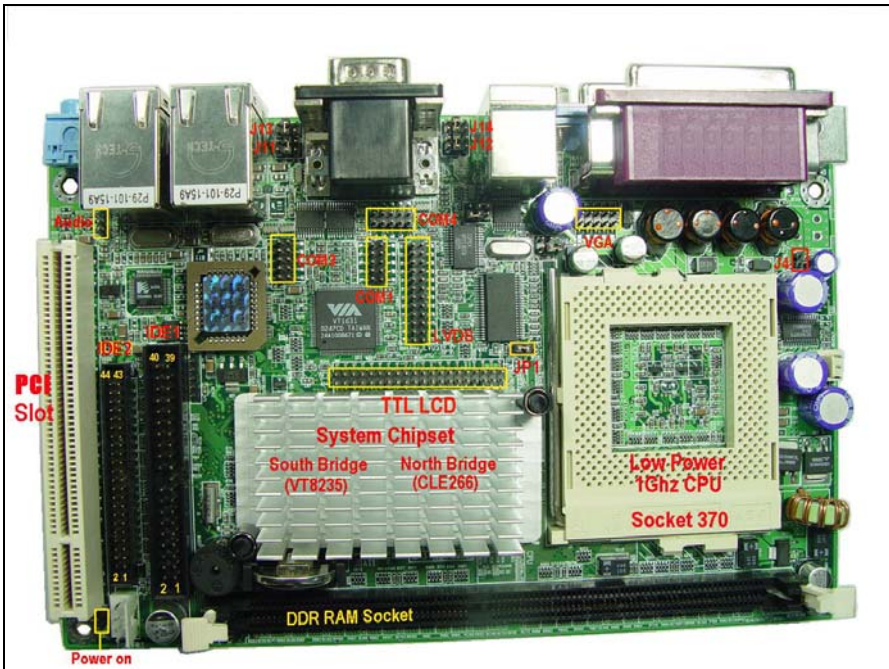

◆ Clear CMOS Setting Select: JBAT1

Function	JP1
Normal (Default)	1-2
Clear CMOS	2-3

• Figure:



◆ LCD Panel Voltage Select: JP1

Function	JP1
5V	1-2
3.3V	2-3

• Figure:



◆ COM2 RS232/422/485 Setting Select: JP2

Function	J6		J7		J8	
	1-2	2-3	1-2	2-3	1-2	3-4
RS-232	On	Off	Off	On	Off	Off
RS-422/485	Off	On	On	Off	On	On

• Figure:

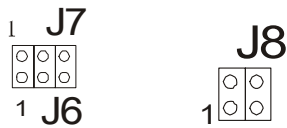

◆ J11 COM4 Setting Select: J11

This jumper setting is select pin9 function.

Function	JP11
+5V	1-2
RI (Default)	3-4
+12V	5-6

• Figure:

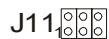

◆ **J12 COM1 Setting Select: J12**

This jumper setting is select pin9 function.

Function	JP11
+5V	1-2
RI (Default)	3-4
+12V	5-6

• Figure:

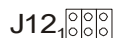

◆ **J13 COM3 Setting Select: J13**

This jumper setting is select pin9 function.

Function	JP11
+5V	1-2
RI (Default)	3-4
+12V	5-6

• Figure:

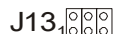

◆ **J14 COM2 Setting Select: J14**

This jumper setting is select pin9 function.

Function	JP11
+5V	1-2
RI (Default)	3-4
+12V	5-6

• Figure:



Chapter 4 Connector's Description

4-1 Connector Location

Table for Connector's Location Description:

Use the information in the following table to change the connector.

Connectors	Functions
IDE1	Primary IDE Connector
IDE2	Secondary IDE Connector
FAN1	Power Fan Connector
TTL	LCD Panel Signal Connector
LVDS	LVDS Panel Signal Connector
JVGA	VGA Signal Pin-Header Connector
JCOM1	COM1 Pin-Header Connector
COM3	COM3 Pin-Header Connector
COM4	COM4 Pin-Header Connector
IR1	IR Pin-Header Connector
J10	Audio Pin-Header Connector
CN9	Parallel Port Connector
Power1	Power Din Connector
KB1	Keyboard/Mouse Connector
S-Video	S-Video TV-out Connector
COM1-2	COM1/2 RS-232 Serial Port Connector
LINO1	Audio Line-out Connector
U12	LAN & USB1/2 Connector
U13	LAN & USB3/4 Connector
VGA1	CRT VGA Port Connector

◆ **Primary IDE Connector (40-pin 2.54mm Pitch Pin-Header with Housing): IDE1**

Pin #	Assignment	Pin #	Assignment
1	Reset IDE	2	Ground
3	Host Data 7	4	Host Data 8
5	Host Data 6	6	Host Data 9
7	Host Data 5	8	Host Data 10
9	Host Data 4	10	Host Data 11
11	Host Data 3	12	Host Data 12
13	Host Data 2	14	Host Data 13
15	Host Data 1	16	Host Data 14
17	Host Data 0	18	Host Data 15
19	Ground	20	No Connect
21	DRQ 0	22	Ground
23	Host IOW	24	Ground
25	Host IOR	26	Ground
27	IOCHRDY	28	Host ALE
29	DACK 0	30	Ground
31	IRQ 14	32	No Connect
33	Address 1	34	No Connect
35	Address 0	36	Address 2
37	Chip Select 0	38	Chip Select 1
39	Activity	40	Ground

• **Figure:**

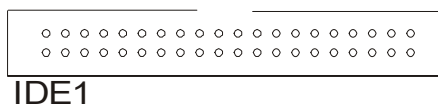

◆ **Secondary IDE Connector (44-pin 2.00mm Pitch Pin-Header with Housing): IDE2**

Pin #	Assignment	Pin #	Assignment
1	Reset IDE	2	Ground
3	Host Data 7	4	Host Data 8
5	Host Data 6	6	Host Data 9
7	Host Data 5	8	Host Data 10
9	Host Data 4	10	Host Data 11
11	Host Data 3	12	Host Data 12
13	Host Data 2	14	Host Data 13
15	Host Data 1	16	Host Data 14
17	Host Data 0	18	Host Data 15
19	Ground	20	No Connect
21	DRQ 1	22	Ground
23	Host IOW	24	Ground
25	Host IOR	26	Ground
27	IOCHRDY	28	Host ALE
29	DACK 1	30	Ground
31	IRQ 15	32	No Connect
33	Address 1	34	No Connect
35	Address 0	36	Address 2
37	Chip Select 0	38	Chip Select 1
39	Activity	40	Ground
41	+5V	42	+5V
43	Ground	44	No Connect

• **Figure:**

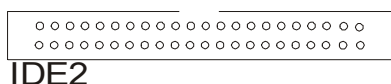

◆ CPU Fan Connector: FAN1

Pin #	Assignment
1	Ground
2	+12V
3	Fan Status Signal

• Figure:



◆ LCD Panel Signal Pinout: JTTL1(24BIT)

Pin #	Assignment	Pin#	Assignment
1	B0	2	B1
3	B2	4	B3
5	G4	6	G5
7	R2	8	R3
9	B4	10	B5
11	B6	12	B7
13	G6	14	G7
15	R4	16	R5
17	G0	18	G1
19	G2	20	G3
21	R0	22	R1
23	R6	24	R7
25	ENPVDD	26	Data Clock
27	ENPVEE	28	Data Enable
29	FPBKLP	30	H-Sync
31	GND	32	V-Sync
33	GND	34	Power Good
35	GND	36	PVDD
37	GND	38	PVDD
39	GND	40	PVDD

◆18Bit LCD Panel Pinout

BLUE	GREEN	RED
B0 → NC	G0 → NC	R0 → NC
B1 → NC	G1 → NC	R1 → NC
B2 → B0	G2 → G0	R2 → R0
B3 → B1	G3 → G1	R3 → R1
B4 → B2	G4 → G2	R4 → R2
B5 → B3	G5 → G3	R5 → R3
B6 → B4	G6 → G4	R6 → R4
B7 → B5	G7 → G5	R7 → R5

• Figure:



◆ LVDS Panel Signal Pinout: LVDS

Pin#	Assignment	Pin#	Assignment
1	PVDD	2	A4-
3	PVDD	4	A4+
5	A0-	6	A5-
7	A0+	8	A5+
9	A1-	10	A6-

11	A1+	12	A6+
13	A2-	14	A7-
15	A2+	16	A7+
17	A3-	18	CLK2-
19	A3+	20	CLK2+
21	CLK1-	22	GND
23	CLK1+	24	GND

• Figure:

JLVDS1



◆ **VGA Connector Pinout: JVGA**

Pin #	Assignment	Pin #	Assignment
1	Red	2	Serial Date
3	Green	4	Serial CLK
5	Blue	6	GND
7	V_SYNC	8	GND
9	H_SYNC	10	GND

• Figure:

JVGA1



◆ **JCOM1 Connector (2.00mm Pin-Header) : JCOM1**

Pin #	Assignment	Pin #	Assignment
1	DCD (Data Carrier Detect)	2	RXD (Receive Data)
3	TXD (Transmit Data)	4	-DTR (Data Terminal Ready)
5	Ground	6	-DSR (Data Set Ready)
7	-RTS (Request to Send)	8	-CTS (Clear to Send)
9	RI (Ring Indicator)	10	No Connect

• Figure:



◆ **COM3 Connector (2.00mm Pin-Header) : COM3**

Pin #	Assignment	Pin #	Assignment
1	DCD (Data Carrier Detect)	2	RXD (Receive Data)
3	TXD (Transmit Data)	4	-DTR (Data Terminal Ready)
5	Ground	6	-DSR (Data Set Ready)
7	-RTS (Request to Send)	8	-CTS (Clear to Send)
9	RI (Ring Indicator)	10	No Connect

• Figure:

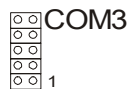

◆ **COM4 Connector (2.00mm Pin-Header) : COM4**

Pin #	Assignment	Pin #	Assignment
1	DCD (Data Carrier Detect)	2	RXD (Receive Data)
3	TXD (Transmit Data)	4	-DTR (Data Terminal Ready)
5	Ground	6	-DSR (Data Set Ready)
7	-RTS (Request to Send)	8	-CTS (Clear to Send)
9	RI (Ring Indicator)	10	No Connect

• **Figure:**



◆ **IR Connector (2.00mm Pin-Header) : IR1**

Pin#	Assignment
1	Vcc+5V
2	No Connect
3	IRTx
4	GND
5	IRTx

• **Figure:**



◆ **Audio Connector (2.00mm Pin-Header) : J10**

Pin #	Assignment	Pin #	Assignment
1	RIGHT	2	LEFT
3	GND	4	MIC1
5	NC		

• **Figure:**



◆ **Parallel Port Connector :CN9**

Pin #	Assignment	Pin #	Assignment
1	Line Printer Strobe	2	PD 0, Parallel Data 0
3	PD 1, Parallel Data 1	4	PD 2, Parallel Data 2
5	PD 3, Parallel Data 3	6	PD 4, Parallel Data 4
7	PD 5, Parallel Data 5	8	PD 6, Parallel Data 6
9	PD 7, Parallel Data 7	10	ACK, Acknowledge
11	Busy	12	Paper Empty
13	Select	14	Auto Feed
15	Error	16	Initialize
17	Select	18	Ground
19	Ground	20	Ground
21	Ground	22	Ground
23	Ground	24	Ground
25	Ground	26	N/A

• **Figure:**

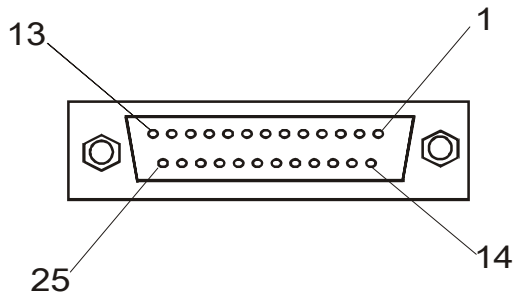

◆ DC+19V Power DIN Connector :Power1

Pin #	Assignment	Pin #	Assignment
1	+19V	4	+19V
3	Ground	4	Ground

• Figure:



◆ PS/2 Keyboard Connector (Mini Din 6 Pin):KB1

Pin #	Assignment	Pin #	Assignment
1	Keyboard Data	2	NC
3	Ground	4	+5V
5	Keyboard Clock	6	NC

◆ PS/2 Mouse Connector (Mini Din 6 Pin):

Pin #	Assignment	Pin #	Assignment
1	NC	2	Mouse Data
3	Ground	4	+5V
5	NC	6	Mouse Clock

• Figure:

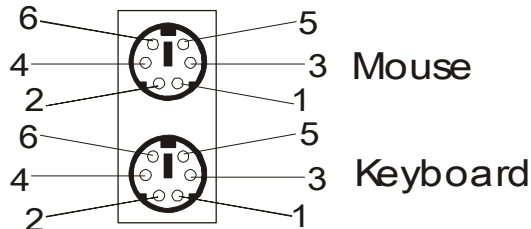

◆ S-Video Connector (Mini Din 4 Pin):S-Video

Pin #	Assignment	Pin #	Assignment
1	Ground	2	Ground
3	LUM	4	CHROM

• Figure:

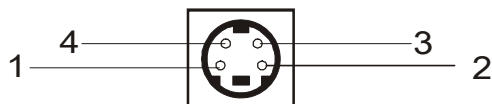

◆ COM1 RS-232 Serial Port Connector (D-SUB 9-pin Male): COM1-2

Pin #	Assignment	Pin #	Assignment
1	DCD (Data Carrier Detect)	2	RXD (Receive Data)
3	TXD (Transmit Data)	4	DTR (Data Terminal Ready)
5	Ground	6	DSR (Data Set Ready)
7	RTS (Request to Send)	8	CTS (Clear to Send)
9	RI (Ring Indicator)		

◆ **COM2 RS-232 Serial Port Connector (D-SUB 9-pin Male): COM1-2**

Pin #	Assignment	Pin #	Assignment
1	DCD (Data Carrier Detect)	2	RXD (Receive Data)
3	TXD (Transmit Data)	4	DTR (Data Terminal Ready)
5	Ground	6	DSR (Data Set Ready)
7	RTS (Request to Send)	8	CTS (Clear to Send)
9	RI (Ring Indicator)		

• **Figure:**

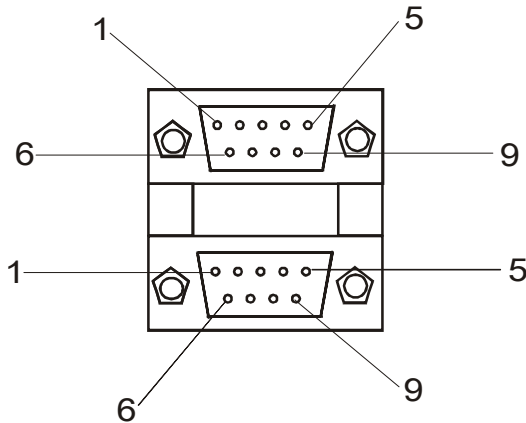

◆ **Audio Connector (3.5mm Phone Jack): LINO1**

Pin #	Assignment	Pin #	Assignment
1	Lineout-R	2	Ground
3	Ground	4	Lineout-L

• **Figure:**

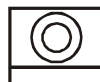

◆ **LAN1 & USB1/2 Connector : U12**

Pin #	Assignment	Pin #	Assignment
LAN			
1	Transmit Data (+)	5	NC
2	Transmit Data (-)	6	Receive Data (-)
3	Receive Data (+)	7	NC
4	NC	8	NC
USB			
1	VCC	2	USB Data-
3	USB Data+	4	Ground

• **Figure:**



◆ **LAN1 & USB3/4 Connector : U13**

LAN			
Pin #	Assignment	Pin #	Assignment
1	Transmit Data (+)	5	NC
2	Transmit Data (-)	6	Receive Data (-)
3	Receive Data (+)	7	NC
4	NC	8	NC

USB			
Pin #	Assignment	Pin #	Assignment
1	VCC	2	USB Data-
3	USB Data+	4	Ground

• Figure:



◆ CRT VGA Port Connector (D-SUB 15-pin Female): VGA1

Pin #	Assignment	Pin #	Assignment
1	Red Color Signal	2	Green Color Signal
3	Blue Color Signal	4	NC
5	Ground	6	Ground
7	Ground	8	Ground
9	NC	10	Ground
11	NC	12	VGA DDA
13	H-Sync.	14	V-Sync.
15	SPCLK		

• Figure:

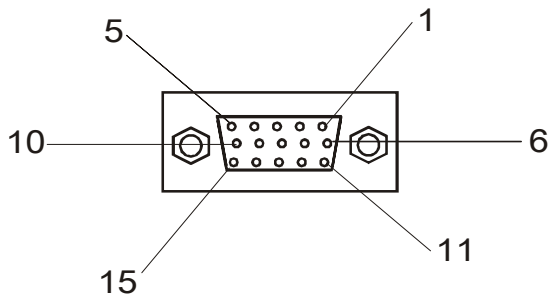

Chapter 5 Power Supply

5-1 Pictures of Power Supply



INPUT : AC 100 - 240V, 2A, 50/60Hz

OUTPUT : DC 18-24V, 4.75A & 90W MAX

Remark:

The following custom-designed DC-DC power supplies are available for customer's request at a reasonable extra cost :

- 1) 12V DC**
- 2) 24V DC**
- 3) 48V DC**
- 4) 72V DC or up**

Chapter 6 Touch Panel

6-1 Touch Panel Description

1. Application

2. Warranty

3. Features

4. Characteristics

- 4.1 Usable Temperature Range
- 4.2 Storage Temperature Range
- 4.3 Input Method

5. Electrical Specifications

- 5.1 Linearity
- 5.2 Insulation Resistance
- 5.3 Chattering Time

6. Mechanical Specifications

- 6.1 Operating Force (with pen)
- 6.2 Surface Hardness

7. Optical Specifications

- 7.1 Light Transmittance

8. Reliability

- 8.1 Line drawing operation
- 8.2 Pen hitting operation

9. Environment Durability Performance

- 9.1 High Temperature Test
- 9.2 Low Temperature Test
- 9.3 Humidity Test
- 9.4 Thermal Shock Test
- 9.5 Resistance to Chemical

10. Quality Level

- 10.1 Inspection condition
- 10.2 Criterion
- 10.3 Glass Fragment
- 10.4 Newton ring

11. Cautions

1. Application : This specification is applied to 5 or 6wire Touch Panel.
2. Warranty : TOUCH PANEL products manufactured to this specification shall be capable of meeting all characteristics for a minimum period of 12 months the date of shipping from NAGASAKI IPC when stored or used as specified under normal conditions within the contents of these sheets. If TOUCH PANEL products are not stored or used as specified herein, it will be void the 12 months warranty.
3. Features
 - Type : Analog Resistive Type Touch Panel
 - Input Mode : Polyester Pen or Finger
 - Structure : Film----- ITO Film Glass----ITO Glass
4. Characteristics
 - 4.1 Operating Temperature Range : From -20 to 60 (Humidity 90%RH or lower, no dew condition shall be acceptable)
 - 4.2 Storage Temperature Range : From -30 to 70 (Humidity 90%RH or lower, no dew condition shall be acceptable)
 - 4.3 Input Method :
 - (1) with Polyester Pen :
Operation and measurement with a pen must be carried out under the following trip condition :

Material : Polyester Tip : SR 0.8 millimeter

(2) with Finger :

Operation and measurement with a finger must be carried out under the

Material : Silicon rubber (Hardness: 60° Hs)

Tip : SR 12.5 millimeter

5. Electrical Specifications

5.1 Linearity Direction : $\pm 1.5\%$ or less (with calibration controller)

5.2 Insulation Resistance : 20 M Ω or more @ DC 25V

5.3 Chattering Time : 10 millisecond or less @ 100K Ω

6. Mechanical Specifications

Item No. Item Ratings Test Methods & Condition

6.1 Operating Force (with Polyester Pen SR 0.8)

According to applicable product specification Less than 150g Using a load cell with a Polyester Pen conforming to the specifications set forth in item 4.3 (1) attached to its tip, apply a vertical load within the valid area. Using the measurement circuit illustrated in diagram 6-1 below, take the gauge value when the voltage value 4.5V or greater as the pressure load value.

6.2 Surface Hardness : 2H or Higher JIS-K5400

7. Optical Specifications

7.1 Light Transmittance (Total Transmittance) : More than 78% (Measuring apparatus : Haze meter-made by BYK-Gardner

Type : Haze-Gard-plus 4726 Illuminant : CIE-A Standard : ASTM D 1003)

8. Reliability Item No. Item Ratings Test Methods & Condition

8.1 Line drawing operation 1,000,000 times of drawing Requirement in paragraph 5 and 6 Drawing must occur in following manner at any point within an Action area.

1) Testing equipment : Pen plotter

2) Testing load / force : 2.5 N

3) Sliding speed : 200 mm / second

4) Tip probe : Polyester Pen as defined in sub-paragraph 4-3 (1)

8.2 Pen hitting operation 5,000,000 hits with a pen Requirement in paragraph 5 and 6 Hits must be made in the following manner at any point within at effective area.

1) Testing equipment : Pen plotter

2) Testing load : 2.5 N

3) Press speed : 3 hits / second

4) Tip probe : Polyester Pen as defined in sub-paragraph 4-3 (1)

9. Environment Durability Performance Item No. Item Ratings Test Methods & Condition

9.1 High Temperature Test Requirement in paragraph 5 and 6: Put it in a vessel at the condition of 70 ± 1 and $45 \pm 1\%$ humidity relative for 120 hours. Moreover let it alone for 24 hours or more in a room temperature and measure it.

9.2 Low Temperature Test Requirement in paragraph 5 and 6: Put it in a vessel at the condition of -30 ± 1 for 120 hours. Moreover, let it alone for 24 hours or more in a room temperature and measure it.

9.3 Humidity Test Requirement in paragraph 5 and 6: Leave in an environment of 60 ± 1 and $90 \pm 1\%$ relative humidity for 120 hours and then perform measurements after leaving at room temperature for 24 hours

9.4 Thermal Shock Test Requirement in paragraph 5 and 6: Put it in a vessel at the condition of 70 ± 1 for 30 minutes and then -30 ± 1 for 30minutes and his process is repeated by 10cycles. Moreover let it alone for 24 hours in a room temperature and measure it.

9.5 Resistance to chemicals (Surface hard coating) No abnormality in external appearance Lightly wipe the surface with methyl alcohol, artificial perspiration or household cleanser (neutral).

10. Quality Level

10.1 Inspection Condition The inspection shall be performed by using Back light 150-300 cd/m² ,1000-1400 Lux (natural light) under the surface of sensor. The panel shall be position sensors from 45cm form eyes and an Angle 30 degree (15~45), 15 second viewing time.

10.2 Criterion The followings are applied to viewing area The item 10.2 (1,2,3,4) should apply to the VA (view area) unless none VA affect electrical performance

(1) Scratch

Width 0.1mm and length 20mm : Accept .

Width > 10 mm or Length > 20mm : Reject

(2) Granular foreign object

Diameter 0.5mm : Acceptable

0.5mm < Diameter : Unacceptable

(3) Linear foreign object (fiber)

Width 0.05 and Length 5mm : Accept

Width 0.05 and Length > 5mm : Unacceptable

(4) Blistering (Puffiness, Baggy) Check through any 0.5millimeter gauge whether a Touch Panel surface film does not contact a measuring face.0.5mm gauge 0.5mm Tablet

10.3 Glass Fragment

(1) Corner Fragment a 2mm ; b 2mm and (c: break height t) : It is acceptable two (t : Glass Thickness)

(2) Side Fragment a 3mm , b 2.0mm and c 1/2t : acceptable five and interval of faults is 20mm minimum every side. (t : Glass Thickness)

10.4 Newton ring

Diameter 35mm · Acceptable

Pass if defect that fails size cannot be seen when held in front of colors program on monitor.

11.Cautions Item No. Subject Note

11.1 Storage 1) Store Touch Panel at the stated temperature and humidity range.

2) Store Touch Panel with original packing.

3) Do not expose Touch Panel directly to the sun

11.2 Unpacking 1) Do not hold FPC / Copper tail to take Touch Panel out of the package.

2) Open the package after checking "UP / DOWN" mark.

3) Do not put the heavy shock and stress on Touch Panel.

11.3 Handling 1) Wear gloves at handling to prevent stains on Touch Panel or injury by the sharp edge of touch glass.

2) Do not hold FPC / Copper while handling Touch Panel.

3) Do not pile Touch Panels and put heavy matter on Touch Panel.

4) Do not add any stress on touch film.

5) Use dry cloth or soft cloth with alcohol, neutral detergent or one with ethanol at cleaning in case of dirt.

6) Do not use organic solvents except alcohol. 11.4 Assembling 1) Avoid excessive force on the Touch Panel.

7) Do not give unnecessary strain to the FPC / Copper tail while assembling.

PnP / PCI Configuration:

This entry appears if your system supports PnP / PCI. See section 6 for the details.

PC Health Status:

Use this menu to show your system temperature, speed and voltage status.

Frequency/Voltage Control:

Use this menu to specify your settings for frequency/voltage control. See section 7 for the details.

Load Fail-Safe Defaults:

Use this menu to load the BIOS default values for the minimal/stable performance for your system to operate. See section 8 for the details.

Load Optimized Defaults:

Use this menu to load the BIOS default values that are factory settings for optimal performance system operations. While Award has designed the custom BIOS to maximize performance, the factory has the right to change these defaults to meet their needs. See section 8 for the details.

Supervisor/User Password:

Use this menu to set User and Supervisor Passwords. See section 9 for the details.

Save & Exit Setup:

Save CMOS value changes to CMOS and exit setup. See section 10 for the details.

Exit Without Save:

Abandon all CMOS value changes and exit setup. See section 10 for the details.

7-3 Standard CMOS Features

The items in Standard CMOS Setup Menu are divided into 10 categories. Each category includes no, one or more than one setup items. Use the arrow keys to highlight the item and then use the <PgUp> or <PgDn> keys to select the value you want in each item.

Standard CMOS Features

Date (mm:dd:yy):	Mon, Aug 6 2003	Item Help
Time (hh:mm:ss):	16:19:20	
➤ IDE Primary Master		Menu Level ➤
➤ IDE Primary Slave	2557 MB	
➤ IDE Secondary Master	None	Change the day, month, year and century
➤ IDE Secondary Slave	None	
Video		
Halt On	EGA/VGA All, But Keyboard	
Based Memory		
Extended Memory	640K	
Total Memory	64512K 65536K	
↑↓←→Move Enter: Select +/-/PU/PD: Value F10: Save ESC: Exit F1: General Help F5: Previous Values F6: Fail-safe defaults F7: Optimized Defaults		

Date: Options Month/DD/YYYY

Set the system date. Note that the 'Day' automatically changes when you set the date.

Time: Options HH : MM : SS

Set the system time.

IDE Primary Master: Options are in its sub menu (described in Table 3)

Press <Enter> to enter the sub menu of detailed options.

IDE Primary Slave: Options are in its sub menu (described in Table 3)

Press <Enter> to enter the sub menu of detailed options.

IDE Secondary Master: Options are in its sub menu (described in Table 3)

Press <Enter> to enter the sub menu of detailed options.

IDE Secondary Master: Options are in its sub menu (described in Table 3)

Press <Enter> to enter the sub menu of detailed options.

Video: Options EGA/VGA/CGA 40/CGA 80/MONO

Select the default video device.

Halt On: Options All Errors/No Errors/All, but Keyboard/All, but Diskette/All,
but Disk/Key

Select the situation in which you want the BIOS to stop the POST process and notify you.

Base Memory: Option N/A

Displays the amount of conventional memory detected during boot up.

Extended Memory: Option N/A

Displays the amount of extended memory detected during boot up

Total Memory: Option N/A

Displays the total memory available in the system

7-4 IDE Adapters

The IDE adapters control the hard disk drive. Use a separate sub menu to configure each hard disk drive.

CMOS Setup Utility – Copyright © 1984 - 2001 Award Software

IDE Primary Master

IDE HDD Auto-Detection	Press Enter	Item Help
IDE Primary Master	Auto 2557 MB	Menu Level >>
Access Mode	Auto	To auto-detect the HDD's size,
Cylinder	4956	head... on this channel
Head	16	
Precomp	0	
Landing Zone	4955	
Sector	63	
↑↓←→Move Enter: Select +/-/PU/PD: Value F10: Save ESC: Exit F1: General Help F5: Previous Values F6: Fail-safe defaults F7: Optimized Defaults		

IDE HDD Auto-detection: Options Press Enter

Press Enter to auto-detect the HDD on this channel. If detection is successful, it fills the remaining fields on this menu.

IDE Primary Master: Options None, Auto and Manual

Selecting "Manual" lets you set the remaining fields on this screen. Selects the type of fixed disk. "User Type" will let you select the number of cylinders, heads, etc. Note: PRECOMP=65535 means NONE !

Capacity: Options Auto Display your disk drive size

Disk drive capacity (Approximated). Note that this size is usually slightly greater than the size of a formatted disk given by a disk-checking program.

Access Mode: Options Normal, LBA, Large and Auto Choose the access mode for this hard disk

The following options are selectable only if the 'IDE Primary Master' item is set to 'Manual'

Cylinder: Options Min = 0, Max = 65535

Set the number of cylinders for this hard disk.

Head: Options Min = 0, Max = 255

Set the number of read/write heads

Precomp: Options Min = 0, Max = 65535

**** **Warning:** Setting a value of 65535 means no hard disk

Landing zone: Options Min = 0, Max = 65535

Sector: Options Min = 0, Max = 255

Number of sectors per track

7-5 Advanced BIOS Features

This section allows you to configure your system for basic operation. You have the opportunity to select the system's default speed, boot-up sequence, keyboard operation, shadowing and security.

CMOS Setup Utility – Copyright © 1984 – 2001 Award Software Advanced BIOS Features

CPU Internal Cache	Enabled	Item Help	
External Cache	Enabled		
CPU L2 Cache ECC Checking	Enabled	<hr/> Menu Level > Allow you to choose the VIRUS warning feature for IDE Hard Disk boot sector protection. If this function is enabled and someone attempt to write data into this area, BIOS will show a warning message on screen and alarm beep	
Quick Power On Self Test	HDD-0		
First Boot Device	CDROM		
Second Boot Device	HDD-1		
Third Boot Device	Enabled		
Boot Other Device	On		
Boot Up NumLock Status	Fast		
Gate A20 Option	Enabled		
Typematic Rate Setting	30		
Typematic Rate (Chars/Sec)	250		
Typematic Delay (Msec)	Setup		
Security Option	Non-OS2		
OS Select For DRAM > 64MB	Enabled		
Video BIOS Shadow	Disabled		
Small Logo (EPA) Show			
↑↓←→Move Enter: Select +/-/PU/PD: Value F10: Save ESC: Exit F1: General Help F5: Previous Values F6: Fail-safe defaults F7: Optimized Defaults			

CPU Internal Cache/External Cache:

These two categories speed up memory access. However, it depends on CPU/chipset design.

Enabled---Enable cache

Disabled---Disable cache

CPU L2 Cache ECC Checking:

This item allows you to enable/disable CPU L2 Cache ECC checking.

The choice: Enabled, Disabled.

Quick Power On Self Test:

This category speeds up Power On Self Test (POST) after you power up the computer. If it is set to Enable, BIOS will shorten or skip some check items during POST.

Enabled---Enable quick POST

Disabled--- Normal POST

First/Second/Third/Other Boot Device:

The BIOS attempts to load the operating system from the devices in the sequence selected in these items.

The Choice: Floppy, LS/ZIP, HDD, SCSI, CDROM and Disabled.

Boot Up NumLock Status:

Select power on state for NumLock.

The choice: On, Off

Gate A20 Option:

Select if chipset or keyboard controller should control GateA20.

Normal---A pin in the keyboard controller controls GateA20

Fast---Lets chipset control GateA20

Typematic Rate Setting:

Keystrokes repeat at a rate determined by the keyboard controller. When enabled, the typematic rate and typematic delay can be selected.

The choice: Enabled, Disabled.

Typematic Rate (Chars/Sec):

Sets the number of times a second to repeat a keystroke when you hold the key down.

The choice: 6, 8, 10, 12, 15, 20, 24 and 30.

Typematic Delay (Msec):

Sets the delay time after the key is held down before it begins to repeat the keystroke.

The choice: 250, 500, 750 and 1000.

Security Option:

Select whether the password is required every time the system boots or only when you enter setup.

System---The system will not boot and access to Setup will be denied if the correct password is not entered at the prompt.

Setup---The system will boot, but access to Setup will be denied if the correct password is not entered at the prompt.

Note: To disable security, select PASSWORD SETTING at Main Menu and then you will be asked to enter password. Do not type anything and just press <Enter>, it will disable security. Once the security is disabled, the system will boot and you can enter Setup freely.

OS Select For DRAM > 64MB:

Select the operating system that is running with greater than 64MB of RAM on the system.

The choice: Non-OS2, OS2.

Video BIOS Shadow:

Set Video BIOS Shadow to memory.

The choice: Enabled, Disabled.

Small Logo (EPA) Show:

Set the Logo (EPA) show or not.

The choice: Enabled, Disabled.

7-6 Advanced Chipset Features

This section allows you to configure the system based on the specific features of the installed chipset. This chipset manages bus speeds and access to system memory resources, such as DRAM and the external cache. It also coordinates communications between the conventional ISA bus and the PCI bus. It must be stated that these items should never need to be altered. The default settings have been chosen because they provide the best operating conditions for your system. The only time you might consider making any changes would be if you discovered that data was being lost while using your system.

Advanced Chipset Features

DRAM Clock/Drive Control	Press Enter	Item Help	
AGP &P2P Bridge Control	Press Enter		
CPU&PCI Bus Control	Press Enter	Menu Level ➤	
Memory Hole	Disabled		
System BIOS Cacheable	Enabled		
Video BIOS Cacheable	Enabled		
VGA Share Memory Size	16M		
Select Display Device	CRT+LCD		
TV_type	NTSC		
TV_Connector	CVBS		
TV_Layout	Default		
Panel Type	02		
↑↓←→Move Enter: Select +/-/PU/PD: Value F10: Save ESC: Exit F1: General Help F5: Previous Values F6: Fail-safe defaults F7: Optimized Defaults			

System BIOS Cacheable:

Selecting “Enabled” allows caching of the system BIOS ROM at F0000h-FFFFFh, resulting in better system performance. However, if any program writes to this memory area, a system error may result.

The choice: Enabled, Disabled.

Video RAM Cacheable:

Select “Enabled” allows caching of the video BIOS, resulting in better system performance. However, if any program writes to this memory area, a system error may result.

The choice: Enabled, Disabled.

Memory Hole:

You can reserve this area of system memory for ISA adapter ROM. When this area is reserved, it cannot be cached. The user information of peripherals that need to use this area of system memory usually discusses their memory requirements.

The choice: Enabled, Disabled.

VGA Share Memory Size:

Select VGA memory size.

The choice: 4M

8M

16M (Default)

32M

Select Display Device:

The chipset has an embedded 32-bit posted write buffer to support delay transactions cycles. Select "Enabled" to support compliance with PCI specification version 2.1.

The choice: Enabled, Disabled.

CRT LCD Switch:

This item allows you to select CRT or LCD display. The default is "CRT Only".

The choice: LCD Only, CRT Only and Simultaneous, CRT Only.

AGP Graphics Aperture Size:

This field determines the effective size of the Graphic Aperture used for a particular GMCH configuration. It can be updated by the GMCH-specific BIOS configuration sequence before the PCI standard bus enumeration sequence takes place. If it is not updated then a default value will select an aperture of maximum size.

The choice: 4, 8, 16, 32, 64, 128 and 256

7-7 Integrated Peripherals

CMOS Setup Utility – Copyright © 1984 – 2001 Award Software
Integrated Peripherals

	Press Enter	Item Help
OnChip IDE Device	Press Enter	
On-Chip Primary PCI IDE	Enabled	
On-Chip Secondary PCI IDE	Enabled	
IDE Primary Master PIO	Auto	Menu Level >
IDE Primary Slave PIO	Auto	If your IDE hard drive supports block mode select Enabled for automatic detection of the optimal number of block read/write per sector the drive can support
IDE Secondary Master PIO	Auto	
IDE Secondary Slave PIO	Auto	
IDE Primary Master UDMA	Auto	
IDE Primary Slave UDMA	Auto	
IDE Secondary Master UDMA	Auto	
IDE Secondary Slave UDMA	Auto	
OnChip PCI Device	Press Enter	
USB Controller	Enabled	
USB Keyboard Support	Disabled	
Onboard Lan Chip	Enabled	
Super IO Device	Press Enter	
Init Display First	PCI Slot	
IDE HDD Block Mode	Enabled	
KBC Input Clock	8MHz	
PWRON After PWR-Fail	Off	
↑↓←→Move Enter: Select +/-/PU/PD: Value F10: Save ESC: Exit F1: General Help F5: Previous Values F6: Fail-safe defaults F7: Optimized Defaults		

OnChip IDE/PCI Device:

The integrated peripheral controller contains an IDE interface with support for two IDE channels. Select "Enabled" to activate each channel separately.

The choice: Press Enter.

OnChip Primary/Secondary PCI IDE:

The integrated peripheral controller contains an IDE interface with support for two IDE channels. Select "Enabled" to activate each channel separately.

The choice: Enabled, Disabled.

IDE Primary/Secondary Master/Slave PIO:

The four IDE PIO (Programmed Input/Output) fields let you set a PIO mode (0-4) for each of the four IDE devices that the onboard IDE interface supports. Modes 0 through 4 provide successively increased performance. In Auto mode, the system automatically determines the best mode for each device.

The choice: Auto, Mode 0, Mode 1, Mode 2, Mode 3 and Mode 4.

IDE Primary/Secondary Master/Slave UDMA:

Ultra DMA/33 implementation is possible only if your IDE hard drive supports it and the operating environment includes a DMA driver (Windows 95 OSR2 or a third-party IDE bus master driver). If your hard drive and your system software both support Ultra DMA/33, select "Auto" to enable BIOS support.

The choice: Auto, Disabled.

USB Controller:

Select "Enabled" if your system contains a Universal Serial Bus (USB) controller and you have USB peripherals.

The choice: Enabled, Disabled.

USB Keyboard Support:

Select "Enabled" if your system contains a Universal Serial Bus (USB) controller and you have a USB keyboard.

The choice: Enabled, Disabled.

Init Display First:

This item allows you to decide to active whether PCI Slot or on-chip VGA first.

The choice: PCI Slot, Onboard.

IDE HDD Block Mode:

Block mode is also called block transfer, multiple commands, or multiple sector read/write. If your IDE hard drive supports block mode (most new drives do), select Enabled for automatic detection of the optimal number of block read/writes per sector the drive can support.

The choice: Enabled, Disabled

KBC Input Clock Mode:

This item allows you to adjust the keyboard input clock.

The choice: 8MHz, 12MHz.

PWRON After PWR-Fail:

This item allows you to select if you want to power on the system after power failure.

The choice: Off, On and Former-Sts.

7-8 Power Management Setup

The Power Management Setup allows you to configure you system to most effectively save energy while operating in a manner consistent with your own style of computer use.

CMOS Setup Utility – Copyright © 1984 – 2001 Award Software

Power Management Setup

ACPI Function	Enabled	Item Help
Power Management	User Define	
Video Off Method	DPMS	
Video Off In Suspend	Yes	Menu Level >
Suspend Type	Stop Grant	
MODEM Use IRQ	NA	
Suspend Mode	Disabled	
HDD Power Down	Disabled	
Soft-Off by PWR-BTTN	Instant-Off	
Wake-Up by PCI card	Disabled	
Power On By Ring	Enabled	
CPU Thermal-Throttling	50.0%	
Resume by Alarm	Disabled	
X Date (of Month) Alarm	0	
X Time (hh:mm:ss) Alarm	0 : 0 : 0	
Reload Global Timer Events		
Primary IDE 0	Disabled	
Primary IDE 1	Disabled	
Secondary IDE 0	Disabled	
Secondary IDE 1	Disabled	
FDD, COM, LPT Port	Disabled	
PCI PIRQ [A-D]#	Disabled	
↑↓←→Move Enter: Select +/-/PU/PD: Value F10: Save ESC: Exit F1: General Help F5: Previous Values F6: Fail-safe defaults F7: Optimized Defaults		

ACPI Function:

This item allows you to enable/disable the Advanced Configuration and Power Management (ACPI).
The choice: Enabled, Disabled.

Power Management:

This category allows you to select the type (or degree) of power saving and is directly related to the following modes:

1. HDD Power Down
2. Doze Mode
3. Suspend Mode

Min. Power Saving:

Minimum power management. Doze Mode = 1 hr. Standby Mode = 1 hr., Suspend Mode = 1 hr., and HDD Power Down = 15 min.

Max. Power Saving:

Maximum power management -- **ONLY AVAILABLE FOR SL CPU's**. Doze Mode = 1 min., Standby Mode = 1 min., Suspend Mode = 1 min., and HDD Power Down = 1 min.

User Defined:

Allow you to set each mode individually. When not disabled, each of the ranges is from 1 min. to 1 hr. except for HDD Power Down, which ranges from 1 min. to 15 min. and disable.

Video Off Method:

This determines the manner in which the monitor is blanked.

V/H SYNC+Blank:

This selection will cause the system to turn off the vertical and horizontal synchronization ports and write blanks to the video buffer.

Blank Screen:

This option only writes blanks to the video buffer.

DPMS:

Initial display power management signaling.

Video Off In Suspend:

This determines the manner in which the monitor is blanked.

The choice: Yes, No.

Suspend Type:

Select the Suspend Type.

The choice: PWRON Suspend, Stop Grant.

MODEM Use IRQ:

This determines the IRQ in which the MODEM can use.

The choice: 3, 4, 5, 7, 9, 10, 11 and NA.

Suspend Mode:

When "Enabled" and after the set time of system inactivity. All devices except the CPU will be shut off.

The choice: Enabled, Disabled.

HDD Power Down:

When "Enabled" and after the set time of system inactivity, the hard disk drive will be powered down while all other devices remain active.

The choice: Enabled, Disabled.

Soft-Off by PWR-BTTN:

Pressing the power button for more than 4 seconds forces the system to enter the Soft-Off state when the system has "hung."

The choice: Delay 4 Sec, Instant-Off.

Wake-Up by PCI Card:

An input signal from PME on the PCI card awakens the system from a soft off state.

The choice: Enabled, Disabled.

Power On by Ring:

An input signal on the serial Ring Indicator (RI) line (in other words, an incoming call on the modem) awakens the system from a soft off state.

The choice: Enabled, Disabled.

CPU Thermal-Throttling:

Select the CPU THRM-Throttling rate.

The choice: 12.5%, 25.0%, 37.5%, 50.0%, 62.5%, 75.0% and 87.5%.

Resume by Alarm:

When “Enabled”, you can set the date and time at which the RTC (real-time clock) alarm awakens the system from Suspend mode.

The choice: Enabled, Disabled.

PM Events:

PM events are I/O events whose occurrence can prevent the system from entering a power saving mode or can awaken the system from such a mode. In effect, the system remains alert for anything, which occurs to a device, which is configured as Enabled, even when the system is in a power down mode.

Primary IDE 0

Primary IDE 1

Secondary IDE 0

Secondary IDE 1

FDD, COM, LPT Port

PCI PIRQ [A-D] #

7-9 PnP/PCI Configurations

This section describes configuring the PCI bus system. PCI, or **P**ersonal **C**omputer **I**nterconnect, is a system, which allows I/O devices to operate at speeds nearing the speed the CPU itself uses when communicating with its own special components. This section covers some very technical items and it is strongly recommended that only experienced users should make any changes to the default settings.

CMOS Setup Utility – Copyright © 1984 - 2001 Award Software

PnP/PCI Configurations

PNP OS Installed	<u>No</u>	Item Help
Reset Configuration Data	Disabled	
Resources Controlled By	Auto (ESCD)	Menu Level ➤
X IRQ Resources	Press Enter	
X DMA Resources	Press Enter	
PCI/VGA Palette Snoop	Disabled	Default is Disabled. Select
PCI Latency Timer (CLK)	32	Enabled to reset Extended System Configuration Data (ESCD) when you exit Setup if you have installed a new add-on and the system reconfiguration has caused such a serious conflict that the OS cannot boot
↑↓←→Move Enter: Select +/-/PU/PD: Value F10: Save ESC: Exit F1: General Help F5: Previous Values F6: Fail-safe defaults F7: Optimized Defaults		

PNP OS Installed:

This item allows you to determine install PnP OS or not.

The choice: Yes, No.

Reset Configuration Data:

Normally, you leave this field Disabled. Select "Enabled" to reset Extended System Configuration Data (ESCD) when you exit Setup if you have installed a new add-on and the system reconfiguration has caused such a serious conflict that the operating system cannot boot.

The choice: Enabled, Disabled.

Resource controlled by:

The Award Plug and Play BIOS has the capacity to automatically configure all of the boot and Plug and Play compatible devices. However, this capability means absolutely nothing unless you are using a Plug and Play operating system such as Windows®95. If you set this field to "Manual" choose specific resources by going into each of the sub menu that follows this field (a sub menu is preceded by a "➤").

The choice: Auto (ESCD), Manual.

IRQ Resources:

When resources are controlled manually, assign each system interrupt a type, depending on the type of device using the interrupt.

DMA Resources:

When resources are controlled manually, assign each system DMA channel a type, depending on the type of device using the DM channel.

PCI/VGA Palette Snoop:

Leave this field at "Disabled".

The choice: Enabled, Disabled.

PCI Latency Timer (CLK):

When enabled this item, the PCI cycle will only be deferred after it has been held in a "Snoop Stall" for 31 clocks and another ADS# has arrived. When disabled, the PCI cycle will be deferred immediately after the GMCH receives another ADS#.

The choice: 0 ~ 255.

7-10 PC Health Status

CMOS Setup Utility – Copyright © 1984 - 2001 Award Software

PC Health Status

CPU Warning Temperature	Disabled	Item Help
Current CPU Fan Speed	5213RPM	
Vtt (V)	1.48V	
Vcore (V)	1.72V	Menu Level ➤
3.3V (V)	3.28V	
+ 5 V	4.97V	
+12 V	12.03V	
-12 V	-12.36V	
-5V	-4.99V	
VBAT (V)	3.07V	
5VSB (V)	4.63V	
↑↓←→Move Enter: Select +/-/PU/PD: Value F10: Save ESC: Exit F1: General Help F5: Previous Values F6: Fail-safe defaults F7: Optimized Defaults		

CPU Warning Temperature:

This item will prevent CPU from overheating.

The choice: Enabled, Disabled.

Current CPUFAN Speed:

Show you the current CPU fan operating speed.

IN0/1/2 (V):

Show you the voltage of Vin (0)/(1)/(2).

+5V/+12V/-12V/-5V:

Show you the voltage of +5V/+12V/-12V/-5V.

7-11 Frequency/Voltage Control

CMOS Setup Utility – Copyright © 1984 - 2001 Award Software

Frequency/Voltage Control

Auto Detect DIMM/PCI CLK	Disabled	Item Help
Spread Spectrum Modulated	Disabled	
CPU Host/PCI Clock	100/33MHz	
CPU Clock Ratio	X 5.5	
<hr/> Menu Level >		
↑↓←→Move Enter: Select +/-/PU/PD: Value F10: Save ESC: Exit F1: General Help F5: Previous Values F6: Fail-safe defaults F7: Optimized Defaults		

Auto Detect DIMM/PCI CLK:

When “Enabled”, this item will auto detect if the DIMM and PCI socket have devices and will send clock signal to DIMM and PCI devices. When disabled, it will send the clock signal to all DIMM and PCI socket.

The choice: Enabled, Disabled.

Spread Spectrum Modulated:

This item allows you to enable/disable the spread spectrum modulated.

The choice: Enabled, Disabled.

CPU Host/PCI Clock:

This item allows you to select CPU Host/PCI Clock.

The choice: 66 ~ 166 MHz.

CPU Clock Ratio:

This item allows you to set up the CPU clock ratio, but this function depends on different CPU performance. It is only effective for those clock ratio haven't been locked.

The choice: X3.0 ~ X8.0.

7-12 Load Fail-Safe Defaults

When you press <Enter> on this item you get a confirmation dialog box with a message similar to:

Load Fail-Safe Defaults (Y/N)?

Pressing “Y” loads the BIOS default values for the most stable, minimal-performance system operations.

7-13 Load Optimized Defaults

When you press <Enter> on this item you get a confirmation dialog box with a message similar to:

Load Optimized Defaults (Y/N)?

Pressing “Y” loads the default values that are factory settings for optimal performance system operations.

7-14 Supervisor/User Password Setting

You can set either supervisor or user password, or both of them. The differences between are:

Set Supervisor Password: can enter and change the options of the setup menus.

Set User Password: just can only enter but do not have the right to change the options of the setup menus. When you select this function, the following message will appear at the center of the screen to assist you in creating a password.

ENTER PASSWORD

Type the password, up to eight characters in length, and press <Enter>. The password typed now will clear any previously entered password from CMOS memory. You will be asked to confirm the password. Type the password again and press <Enter>. You may also press <Esc> to abort the selection and not enter a password.

To disable a password, just press <Enter> when you are prompted to enter the password. A message will confirm the password will be disabled. Once the password is disabled, the system will boot and you can enter Setup freely.

PASSWORD DISABLED

When a password has been enabled, you will be prompted to enter it every time you try to enter Setup. This prevents an unauthorized person from changing any part of your system configuration.

Additionally, when a password is enabled, you can also require the BIOS to request a password every time your system is rebooted. This would prevent unauthorized use of your computer.

You determine when the password is required within the BIOS Features Setup Menu and its Security option (see Section 3). If the Security option is set to “System”, the password will be required both at boot and at entry to Setup. If set to “Setup”, prompting only occurs when trying to enter Setup.

7-15 Exit Selecting

Save & Exit Setup

Pressing <Enter> on this item asks for confirmation:

Save to CMOS and EXIT (Y/N)?

Pressing “Y” stores the selections made in the menus in CMOS – a special section of memory that stays on after you turn your system off. The next time you boot your computer, the BIOS configures your system according to the Setup selections stored in CMOS. After saving the values the system is restarted again.

Exit Without Saving

Pressing <Enter> on this item asks for confirmation:

Quit without saving (Y/N)? Y

This allows you to exit Setup without storing in CMOS any change. The previous selections remain in effect. This exits the Setup utility and restarts your computer.